

APPLICATIONS

The MPCV15 series is an 15" conical vandal resistant fixture that can be mounted on the wall or ceiling. It is designed to provide long life and high reliability in those applications where an extra level of protection and security is required. The housing can be mounted directly over a standard 4" outlet box or surface wired through 1/2" conduit entries. Suitable for wet locations, these lights are typically mounted 8 – 14 feet high.

- ◆ Parking Structures
- ◆ Schools
- ◆ Shopping Centers
- ◆ Correctional Facilities
- ◆ Parks and Swimming Pools Facilities
- ◆ Any Public Building

FEATURES & BENEFITS

- ◆ Uses up to 60% less energy equivalent when compared to the HID
- ◆ Instant on/off operation
- ◆ Resistant to shock and vibration
- ◆ Surged Protected
- ◆ 5000K CCT
- ◆ 80 CRI
- ◆ Unique optical design provides optimum light distribution
- ◆ Up to 100,000 hrs rated life
- ◆ 5 year limited warranty

For photometric data and IES files, please contact the factory.

ORDERING DATA

Model Number	Input Current	Operating Voltage	Lamp Watts
MPCV15IND8050K	240~480mA	100~277 VAC 50/60 Hz	80W

* Other finishes may be available. Contact the factory for details. ‡ Contact factory for details and other options. So that we may continue to supply the best available products, specifications may change. Check our web site for the latest updates and product improvements. Contact our engineering staff if you require further application information.

Dimensions and specifications subject to change without notice.



SPECIFICATIONS

Housing:

Durable die cast aluminum with 1/2" threaded conduit entries for surface wiring. A continuous one piece gasket ensures a weather tight seal.

Lens:

Clear Prismatic polycarbonate diffuser with UV inhibitors

Lamp:

80W round induction lamp

Operating Voltage:

100 ~ 277 VAC 50/60Hz

Finish:

Dark bronze powder paint finish is standard*

Listings / Ratings:



**UNDERWRITERS
LABORATORIES**



IP 66 rated

Conforms to UL1598 & EN61347 safety regulations

◆ 800-444-WATT ◆ www.mobern.com ◆

9731 Washington Blvd. Laurel, MD 20723

CAT#

JOB NAME

TYPE

DIMENSIONS

SIDE VIEW

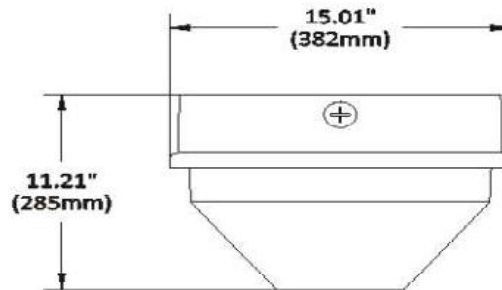

TOP VIEW

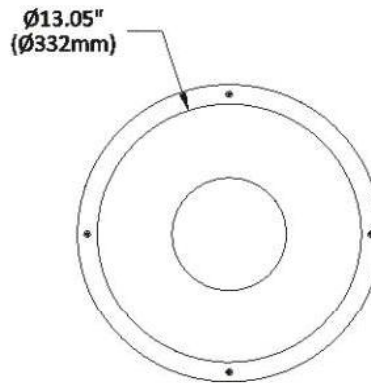

Dimensions and specifications subject to change without notice.