

APPLICATIONS

Commercial, retail and industrial facilities that require AC only or battery backup emergency exit lighting signage. Good for owners of such properties with high utility rates and are looking to save dollars on electricity.

FEATURES & BENEFITS

- ◆ Compact, low-profile design in neutral finish. (also available in black finish).
- ◆ Available in red and green LED
- ◆ Energy consumption of less than 2 watts
- ◆ LED lamp life of 25 years
- ◆ Completely self-contained
- ◆ Installs in minutes with only a screwdriver
- ◆ Standard 120 Volt AC and emergency units available
- ◆ Injection-molded, V-O flame retardant, high-impact, thermoplastic housing
- ◆ 120/277 dual voltage input.
- ◆ Universal snap in and out chevrons meet all new state and local codes
- ◆ Prismatic, louverd downlighting
- ◆ Test switch and light on battery backup
- ◆ Battery backup provided by Ni-cad Battery
- ◆ Self-Diagnostics (Optional)
- ◆ UL Listed for damp locations
- ◆ EZ-snap mounting canopy included for top or end mount
- ◆ Universal K/O pattern on back plate for wall mount



Meets UL924, NFPA 101 Life Safety Code, NEC, OSHA, Local and State Codes.

SPECIFICATIONS

The AC unit only is continuously lighted by the normal AC power. The emergency battery backup models are constantly illuminated by normal AC power. Whenever normal AC current fails, the internal solid state transfer switch automatically connects the internal battery to the LED lamps inside the exit sign to keep it continuously lit for at least 90 minutes.

WARRANTY

Both the MEBX fixture and internal battery carry a warranty of one year to be free from defective material and workmanship from time of shipment. The battery is pro-rated for a 5-year period when operated at normal ambient temperatures.

ORDERING DATA

EXAMPLE: MEBXLRWA1SD

MEBX	L						
Series	LED	Letters	Housing Color	AC/Battery	# of Faces	Options	
MEBX	L LED	R Red Letters G Green Letters	W White Housing B Black Housing	A AC only B Battery Backup	1 Single Face U Universal Plates Single/Double Face	CW Custom Wording	RC Remote Capacity*
						SD Self Diagnostic*	US Made in USA

Dimensions

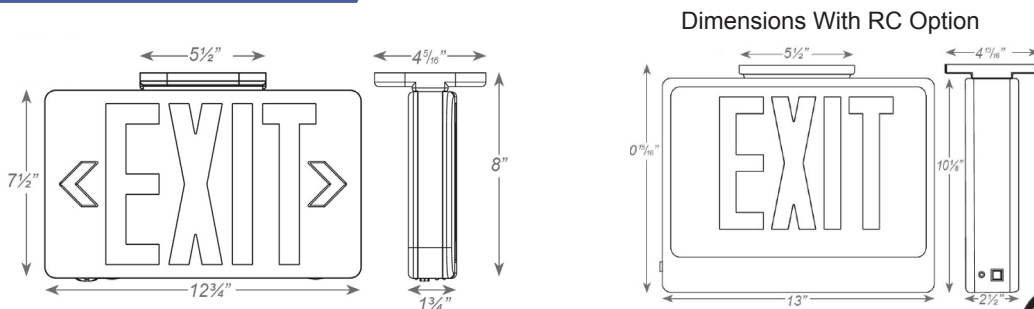

*Only available w/ EM units

RC Option



Dimensions and specifications subject to change without notice.

◆ 800-444-WATT ◆ www.mobern.com ◆
8200 Stayton Dr., Ste. 500, Jessup, MD 20794

CAT#	
JOB NAME	
TYPE	