

FEATURES & BENEFITS

ILLUMINATION

- ◆ Two fully-adjustable 5.4 watt, glare-free lamp heads
- ◆ High-performance reflector and tempered glass lens for optimal light
- ◆ Ultra-bright, energy efficient, long-life Red or Green LED exit sign illumination

ELECTRICAL

- ◆ Dual 120V/277V
- ◆ Charge rate/power "ON" LED indicator light and push-to-test switch for mandated code compliance testing
- ◆ 6V long life, maintenance-free, rechargeable NiCd battery
- ◆ Internal solid-state transfer switch automatically connects the internal battery to LED board and LED lamp heads for minimum 90-minute emergency illumination
- ◆ Fully automatic solid-state, two rate charger initiates battery charging to recharge a discharged battery in 24 hours

MOUNTING

- ◆ Mounting hardware provided for back surface wall mount

HOUSING

- ◆ 5VA flame retardant, UV-stabilized polycarbonate gray finish
- ◆ High impact resistant, UV-stabilized polycarbonate clear lens
- ◆ Corrosion-resistant enclosure engineering grade silicone gasket
- ◆ Top and side K/O's provided for conduit feed applications
- ◆ EZ snap-out chevron directional indicators



OPTIONS

- ◆ HTR: optional internal heater for cold temperature applications

WARRANTY / LISTING

- ◆ Five year warranty on all electronics and housing. Battery pro-rated for five years
- ◆ Meets UL924, NFPA 101 Life Safety Code, NEC, OSHA, Local and State Codes

ORDERING DATA

EXAMPLE: MEBCWLXTE1REMHTR

MEBCWLXTE

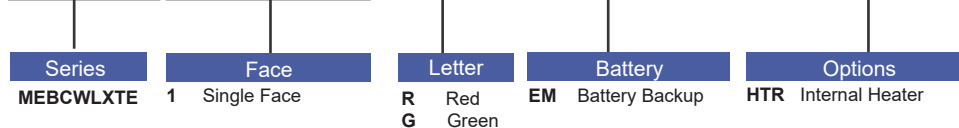

DIMENSIONS

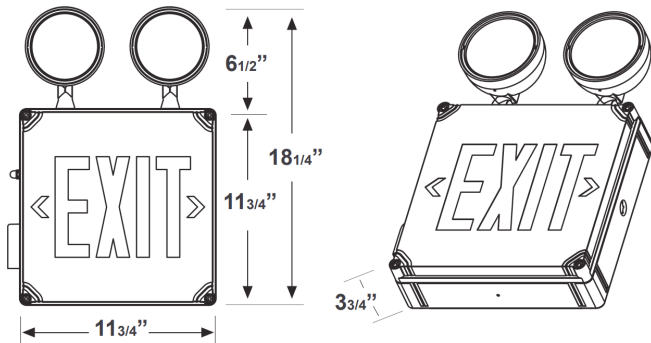

Dimensions and specifications subject to change without notice.



◆ 800-444-WATT ◆ www.mobern.com ◆
8200 Stayton Dr., Ste. 500, Jessup, MD 20794

CAT#	
JOB NAME	TYPE